

# Completion Report Grave of

**PARMANAND MEVARAM RAMCHANDANI**

**2017**

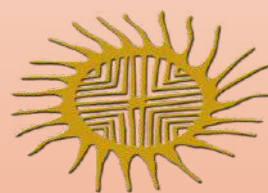
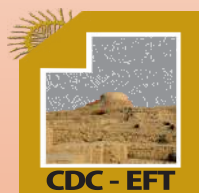

Center for Documentation and Conservation  
of the Heritage of Sindh

Endowment Fund Trust for Preservation  
of the Heritage of Sindh

## PARMANAND MEVARAM RAMCHANDANI

The grave of renowned sindhi writer and lexicographer Parmanand Mevram Ramchandani (1866 - 1938) is being restored by CDC-EFT. He was buried at christian cemetery (Gora Qabarstaan) near Qasim Chowk Hyderabad. After examining the site, related photographs and holding discussion with the Chowkidar and Bishop of the Catholic Church father Mr. Arif, it was confirmed that the said grave belonged to the late legend of Sindhi literature.

All expenditure on the restoration of grave born by the EFT, which is striving for the restoration of historical, buildings, tombs and graves etc.

### مصنف پابيت



پرمائند ميوارام رامچنداڻي: سنڌي ٻوليءَ جي نامياري ليکڪ، محقق ۽ اخبار نويس، جنوري 1866ع ۾ حيدرآباد شهر ۾ جنم ورتو. حيدرآباد کان سواءِ شڪارپور ۽ ڪراچيءَ ۾ تعليم ورتائين. هن ننڍي وهيءَ ۾ نوڪري ڪرڻ شروع ڪئي ۽ ان سانگي ڏيپلي ۽ عمرڪوٽ کان وٺي سکر ۽ شڪارپور تائين جا سفر ڪيا. هن پهريئن سروس ”ماريپور سالٽ ورڪس“ ۾ ڪئي. ان کان پوءِ ڪجهه سال هن ”ليڪراڄ“ ۽ ”ڪيمچند اسڪول“ ۽ ”يونين اڪيڊمي“ ۾ ماستري ڪئي. ماستري ڇڏي هو ”ڊسٽرڪٽ هاءِ ڪورٽ حيدرآباد“ جي ملازمت ۾ گهڙيو ۽ ان کان پوءِ اها به نوڪري ڇڏيائين. بعد ۾ ”سينٽ پيٽرڪ اسڪول“ ۾ استاد مقرر ٿيو. جتي هن مسيحي تعليم کان متاثر ٿي، عيسائي مذهب اختيار ڪيو ۽ سندس نالو ”فيلڪس“ رکيو ويو. انهيءَ عرصي ۾ هن آڪٽوبر 1896ع کان هڪ پندرهن روزه اخبار ”جوت“ نالي سان ڪيڻ شروع ڪئي، جيڪو بنيادي طرح سان هڪ علمي، ادبي ۽ اخلاقي قدرن جو پرچارڪ مخزن هيو. پاڻ اورچ طبع جو مالڪ هو. 42 ورهيه سانده اخبار ”جوت“ هلائڻ واري ڳالهه ان جو ثبوت آهي.

هن پنهنجن تحريرن وسيلي پنهنجي همعصرن ۽ ان دور جي نئين تهئيءَ تي وڏو اثر وڌو. پيرومل مهر چند آڏواڻي سندس مضمون نويسيءَ کان ايترو متاثر هو جو کيس سنڌ جو ”ايڊيسن“ سڏيندو هو. پروفيسر منگهارام کيس پنهنجي ڪتاب، ”سنڌي نثر جي تاريخ“ ۾ اصلوڪي ۽ نچ سنڌي آکاڻيءَ جو خالق ڪري لکيو آهي. هي ڪتاب ”گل ڦل“ پرمائند ميوارام پنن ڀاڱن ۾ 10 نومبر 1925ع ۽ 24 ڊسمبر 1935ع ۾ شايع ڪيو. سندس نصيحتي ۽ ٽوٽڪائي لکڻين تي ٻڌل مواد کي سنڌ جي ”جوينائيل ڪوآپريٽو سوسائٽي“ پاران ”دلپهار“ جي نالي سان ڇپڻ ڀاڱن ۾ ڇپرايو ويو. هن جو سڀ کان وڏو علمي ۽ املهه ڪم ”سنڌي - انگريزي لغت“ ۽ ”انگريزي - سنڌي لغت“ جوڙڻ هو.

1938ع ۾ سندس چالاڻي کان پوءِ سندس اخبار کي سندس شاگرد ۽ هر مذهب فادر اين. ايف ڪيسواڻي ساڳيءَ دلچسپيءَ سان ڪيندو رهيو. 1946ع ۾ ’جوت‘ جي سلور جوبلي پڻ ملهائي وئي ۽ ’جوت‘ جو خاص نمبر ڪڍيو ويو. جنهن ۾ سنڌ جي چوٽيءَ جي ليکڪن جا مضمون ڇپيا ۽ پرمائند ميوارام جي علمي ۽ ادبي حيثيت تي روشني وجهڻ سان گڏوگڏ کيس هڪ عالم طور پيٽا ڏني وئي. هو سنڌ جو يگانو نثر نگار هو، جنهن جي لکڻيءَ ۾ اخلاقي پهلو هميشه چٽو ۽ اجاگر نظر ايندو آهي. سنڌي ٻوليءَ ۾ ادب جي هن مخلص خدمتگذار جي قبر اڄ به حيدرآباد جي گورا قبرستان ۾ موجود آهي. - ن. ا. ش.

PARMANAND MEVARAM RAMCHANDANI

RESTORATION OF THE GRAVE OF  
RENOWNED SINDHI WRITER AND LEXICOGRAPHER  
**PARMANAND MEVARAM RAMCHANDANI**



(1866 - 1938)



**ENDOWMENT FUND TRUST**  
for Preservation of the Heritage of Sindh

**Panaflex for inauguration of grave of Parmanand Mevaram Ramchandani**

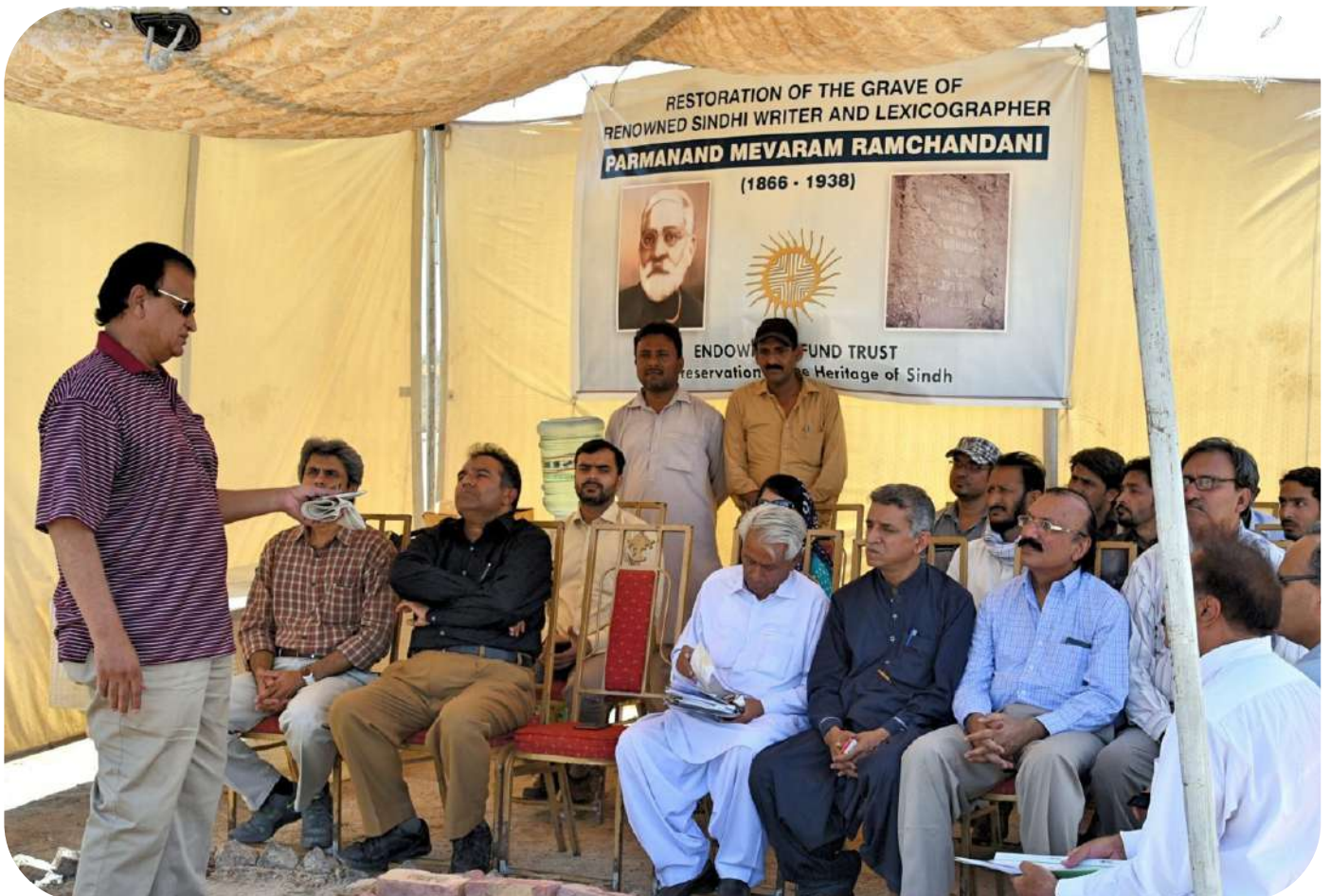

**Regional Coordinator (CDC-EFT) Hyderabad Briefing to Journalist & Writers**

**PARMANAND MEVARAM RAMCHANDANI**



**Mr. Inam Shaikh (Regional Director) Allama Iqbal Open University Hyderabad**

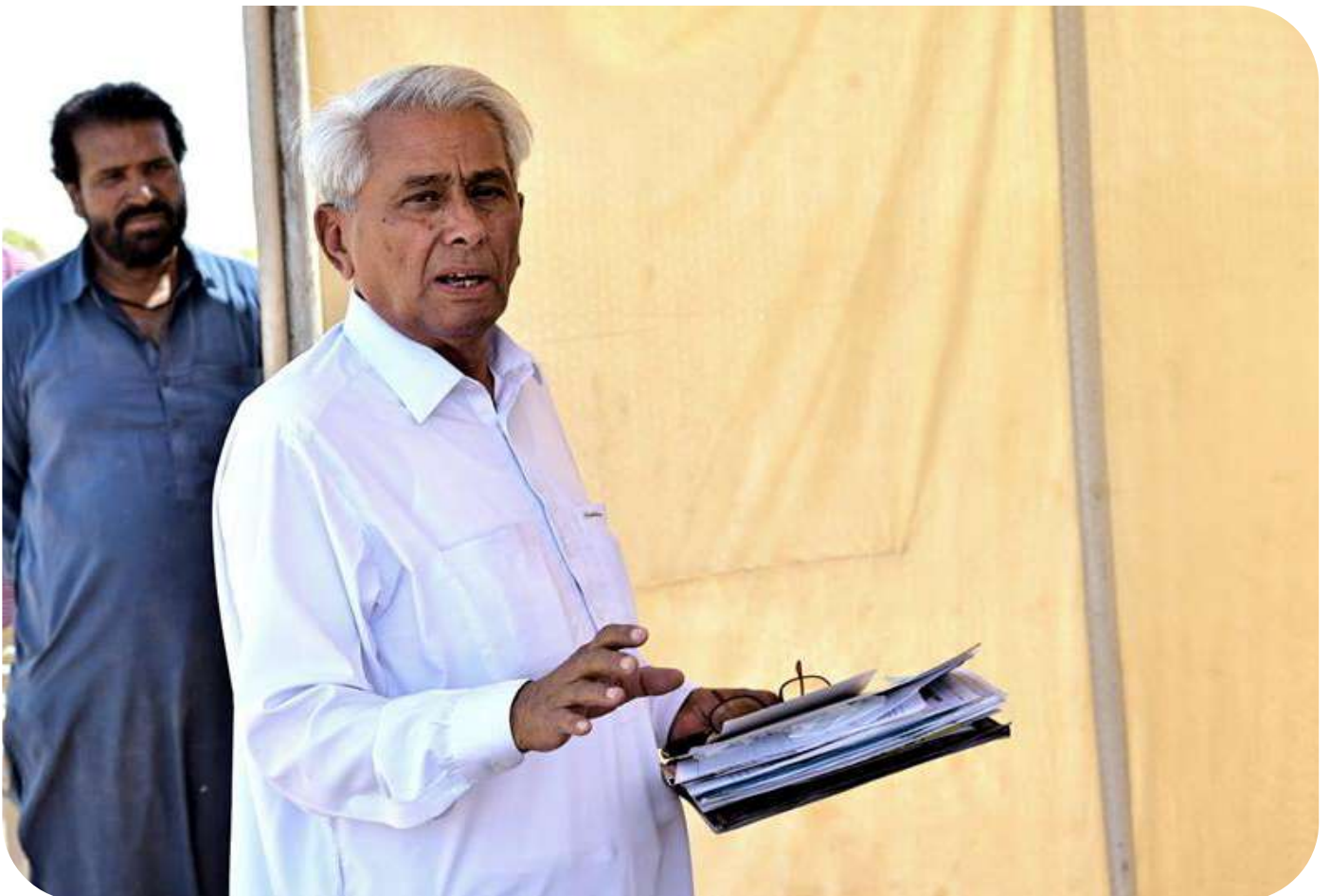

**Mr. Nafees Ahmed Nashad well known senior writer**

# PARMANAND MEVARAM RAMCHANDANI

## Photo gallery



**Mr. Naseer Mirza expressing his views**



**Mr. Mushtaq Shabrani with R.C CDC-EFT, Hyderabad**



**PARMANAND MEVARAM RAMCHANDANI**



**PIC 19 YEARS AGO (1999)**



**PIC AFTER 19 YEARS (2017)**

**Grave firstly discovered by Mr. Nafees Ahmed Nashad  
and the above photograph (1999) was printed in “MEHRAN”**

Architectural Drawings

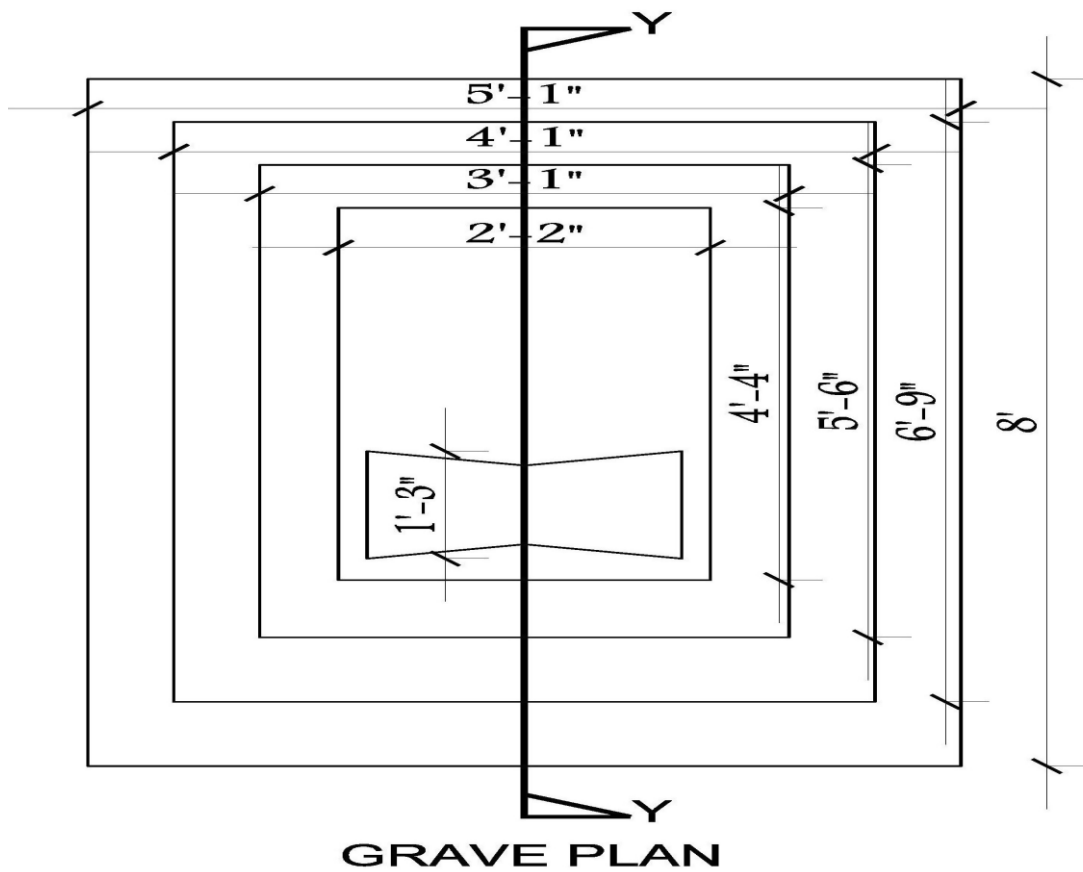
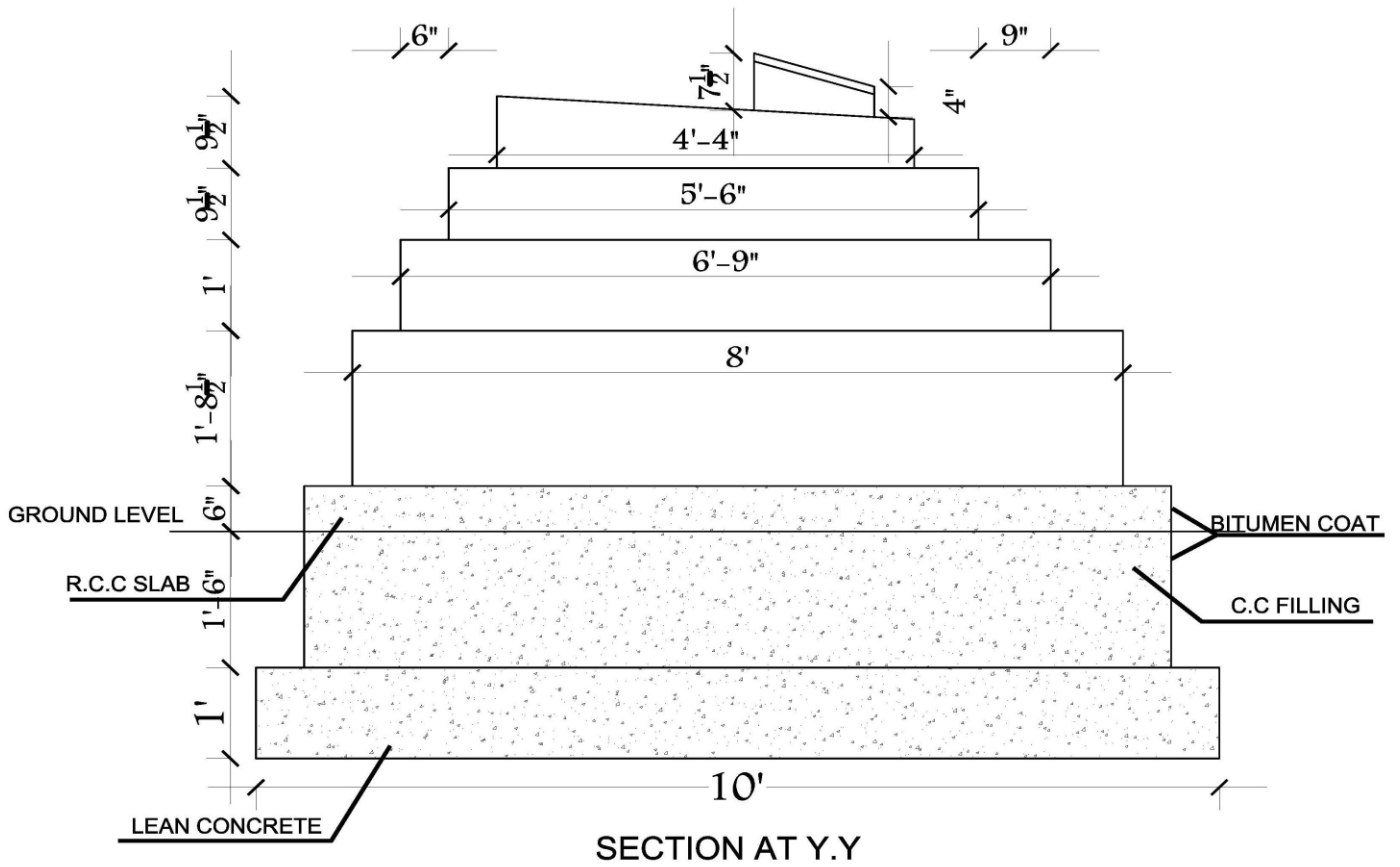

# PARMANAND MEVARAM RAMCHANDANI

## Restoration of Grave

- Lean concrete 1:4:8 has been provided at the base of the grave.
- Masonry work is completed upto proposed level.
- 2-3 coats of bitumen have been provided to the masonry walls to control the dampness.
- Plain cement Concrete 1:2:4 has been laid surrounding the grave.
- Book shaped plate is fixed on the top of grave.
- Marble work is finished.
- Epitaph is placed on the front side of the grave.

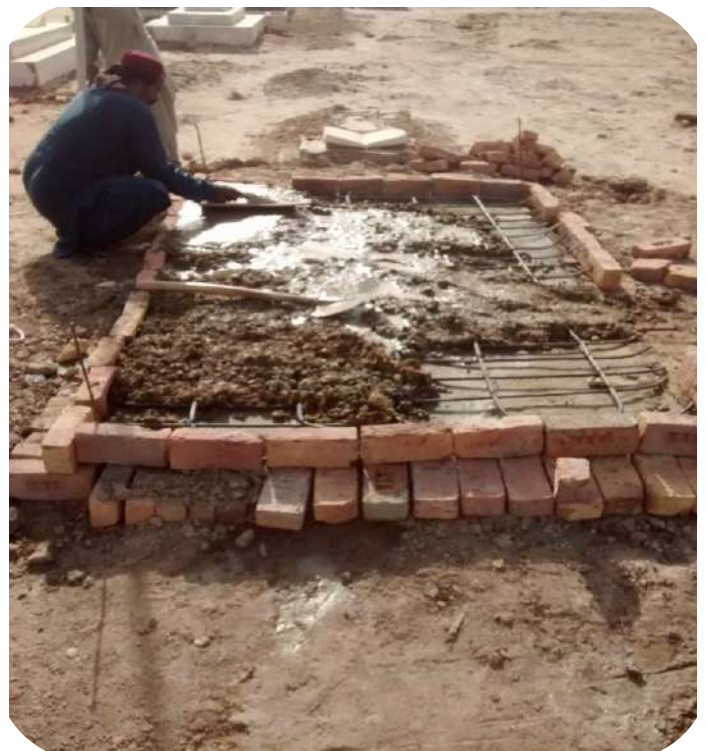

# PARMANAND MEVARAM RAMCHANDANI



# PARMANAND MEVARAM RAMCHANDANI



PARMANAND MEVARAM RAMCHANDANI



# PARMANAND MEVARAM RAMCHANDANI



**PARMANAND MEVARAM RAMCHANDANI**

**Total Expenditure  
Rs: 1,17,495/=**



**Final shape of grave of Parmanand Mevaram Ramchandani after restoration by EFT (2017)**